

Wandcontactdoos

Bestelnr. 108



- schroefklemmen
- binnenliggende bevestiging
- behuizing 180° draaibaar bij 4- en 5-polige uitvoering
- kabelinvoer 1 x boven en 1 x blind onder

Technische informatie

Ampère	16 A
Polen	4 p
Voltage	50-500 V
Uurstand	2 h
Hertz	300-500 Hz
Aansluittechniek	schroefklemmen
Contacten	standaard
Beschermingsgraad	IP 44
Gewicht	236 g
Certificeringen	VDE, EAC

Tekeningen

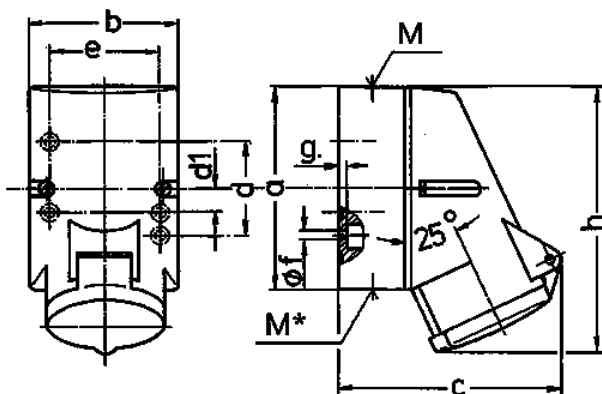

Tekening	Amp.	16		
		Polen		
1 MB 209		3	4	5
Maten in mm				
a		87	100	100
b		64	75	75
c		99	110	113
d		40	-	-
d1		-	11	11
e		50	59	59
f		4,5	5	5
g		4	4	4
h		115	125	128
M		20	20	20
M*		20 (blind) breekpoort		
Kabel Ø tot mm		15	15	15
Kabelaansluiting van/tot mm²		1,5	1,5	1,5
		-4	-4	-4