

## Inbouwcontactdoos TM

Bestelnr. 23176



- schroefklemmen
- hittebestendig binnenwerk
- vernikkelde contacten
- rechte uitvoering (Vorm AS)

### Technische informatie

Ampère	32 A
Polen	5 p
Voltage	50-500 V
Uurstand	2 h
Hertz	300-500 Hz
Aansluittechniek	schroefklemmen
Contacten	hittebestendig binnenwerk, vernikkelde contacten
Beschermingsgraad	IP 67
Flens	85x75 mm
Bevestigingsgaten	60x60 mm
Gewicht	344 g
Certificeringen	VDE, EAC

### Tekeningen

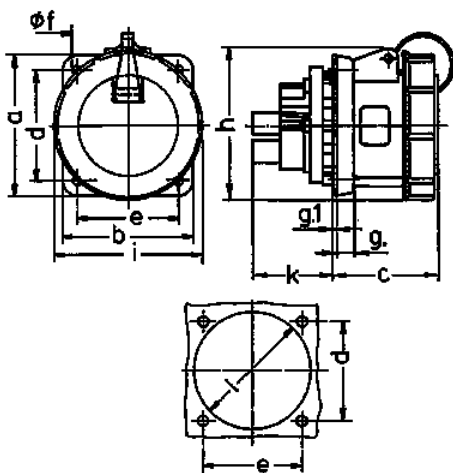

Tekening 1 MB 217/1	Amp. Polen	16		32		63
		3	5	3	5	5
Maten in mm	a	75	75	85	85	107
	b	75	75	75	75	100
	c	60	60	67	73	82
	d	60	60	60	60	85
	e	60	60	60	60	77
	f	5,5	5,5	5,5	5,5	6,5
	g.	8	8	8	8	12
	g.1	2	2	2	2	2
	h	81	95	95	106	115
	i	70	88	94	102	114
	k	26	27	34	34	55
Kabelaansluiting van/tot mm <sup>2</sup>	l	52	57	58	65	88
		1,5	1,5	2,5	2,5	6
		—4	—4	—10	—10	—25