

Inbouwcontactdoos TM

Bestelnr. 23432



- schroefklemmen
- hittebestendig binnenwerk
- vernikkelde contacten
- rechte uitvoering (Vorm AS)

Technische informatie

Ampère	125 A
Polen	5 p
Voltage	400 V
Uurstand	6 h
Hertz	50-60 Hz
Aansluittechniek	schroefklemmen
Contacten	vernikkelde contacten, X-CONTACT®, hittebestendig binnenwerk
Beschermingsgraad	IP 67
Flens	130x130 mm
Bevestigingsgaten	104x104 mm
Gewicht	1371 g
Certificeringen	EAC

Tekeningen

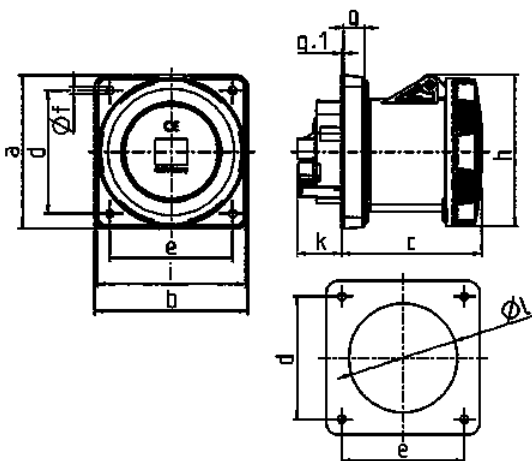

Tekening 1 MB 258	Amp. Polen	125	
		4	5
Maten in mm	a	130	130
	b	130	130
	c	119	119
	d	104	104
	e	104	104
	f	6,5	6,5
	g.	18	18
	g.1	2	2
	h	129	129
	i	126	126
	k	43	43
	l	95	95
Kabelaansluiting van/tot mm ²		25	25
		-70	-70