

## Wandcontactdoos

Bestelnr. 75276



- switched
- electrical interlock
- seawater resistant design available on request

## Technische informatie

Ampère	200 A
Polen	5 p
Voltage	400 V
Uurstand	6 h
Hertz	50-60 Hz
Aansluittechniek	schroefklemmen
Contacten	standaard
Beschermingsgraad	IP 55
Gewicht	31000 g
Certificeringen	EAC

## Tekeningen

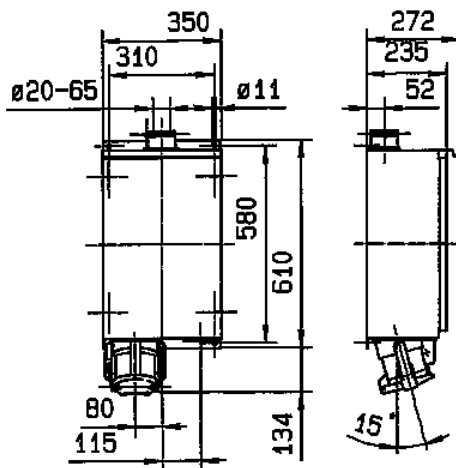

**Tekening  
1 MB 387**

**Maten in mm**