

## Inbouwcontactdoos

Bestelnr. 1276



- schroefklemmen
- Flens: 75 x 75 mm
- bevestigingsgaten: 60 x 60 mm
- rechte uitvoering
- tevens geschikt voor wandgoot en energiezuilen

## Technische gegevens

Ampère	32 A
Polen	5 p
Voltage	400 V
Uurstand	6 h
Hertz	50-60 Hz
Aansluittechniek	schroefklemmen
Contacten	standaard
Beschermingsgraad	IP44
Flens	75x75 mm
Bevestigingsgaten	60x60 mm
Gewicht	232 g
Certificeringen	VDE, EAC

## Afmetingen

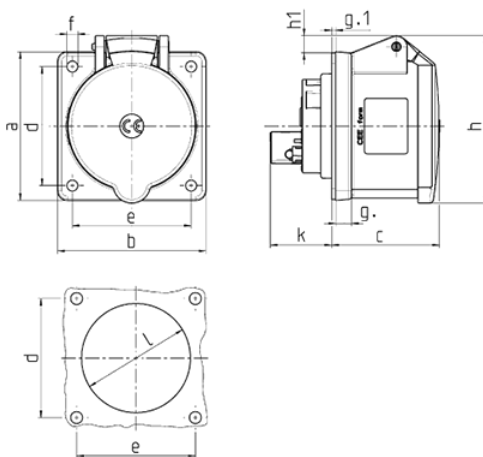

Tekening 1 MB 360	Amp. Polen	16			32		
		3	4	5	3	4	5
<b>Maten in mm</b>							
a		75	75	75	75	75	75
b		75	75	75	75	75	75
c		53	53	55	64	64	64
d		60	60	60	60	60	60
e		60	60	60	60	60	60
f		5,5	5,5	5,5	5,5	5,5	5,5
g.		8	8	8	8	8	8
g.1		2	2	2	2	2	2
h		75	80	85	89	89	95
h1			6	9	11	11	12
k		31	32	32	39	39	17
l		43	52	54	58	58	54
<b>Kabelaansluiting van/tot mm<sup>2</sup></b>							
		1,5	1,5	1,5	2,5	2,5	2,5
		-4	-4	-4	-10	-10	-10