

Inbouwcontactdoos

Bestelnr. 1467



- schroefklemmen
- 20° hoek

Technische gegevens

Ampère	16 A
Polen	4 p
Voltage	400 V
Uurstand	6 h
Hertz	50-60 Hz
Aansluittechniek	schroefklemmen
Contacten	standaard
Beschermingsgraad	IP44
Flens	100x92 mm
Bevestigingsgaten	85x77 mm
Hoek	20°
Gewicht	183 g
Certificeringen	VDE, EAC, Kema, CQC

Afmetingen

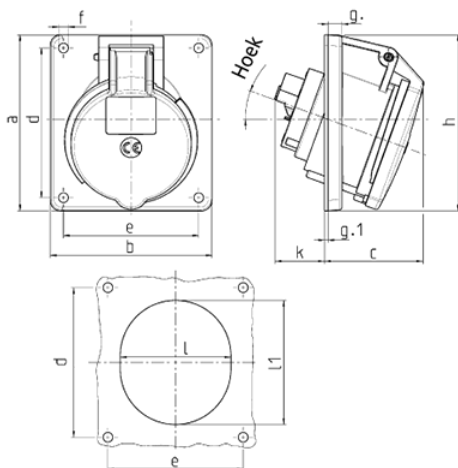

Tekening	Amp.	16			32		
		3	4	5	3	4	5
1 MB 260	Polen						
Maten in mm	a	73,5	100	100	100	100	100
	b	64	92	92	92	92	92
	c	50	59	58	62	62	61
	d	60	85	85	85	85	85
	e	52	77	77	77	77	77
	f	5,5	5,5	5,5	5,5	5,5	5,5
	g.	7	8	8	8	8	8
	g.1	2	2	2	2	2	2
	h	79	100	100	103	103	106
	k	44	34	34	54	54	49
	l	52	55	65	67	67	72
	l1	60	63	72	82	82	85
	α	20°	20°	20°	20°	20°	20°
Kabelaansluiting		1,5	1,5	1,5	2,5	2,5	2,5
van/tot mm²		—4	—4	—4	—10	—10	—10