

## Wandcontactdoos

Bestelnr. 1557



- schroefklemmen
- geschikt voor doorlussen
- binnenbevestiging
- kabelinvoer 1 x boven en 2 x onder (blind)
- behuizing 180° draaibaar

## Technische gegevens

Ampère	32 A
Polen	5 p
Voltage	400 V
Uurstand	6 h
Hertz	50-60 Hz
Aansluittechniek	schroefklemmen
Contacten	standaard
Beschermingsgraad	IP44
Gewicht	400 g
Certificeringen	VDE, EAC, Kema, CQC

## Afmetingen

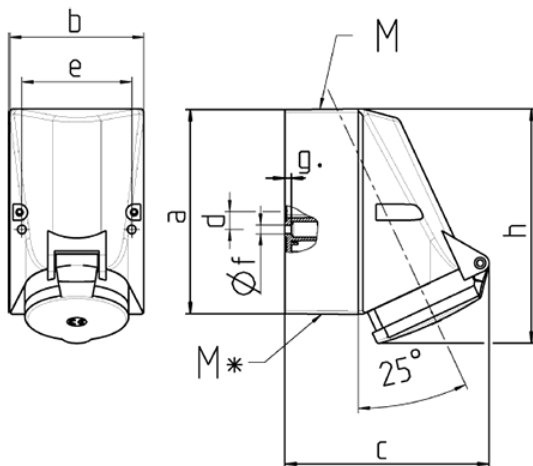

Tekening 1 MB 43	Amp. Polen	16		32			
		4	5	3	4	5	
Maten in mm		a	128	128	128	128	128
		b	84	84	84	84	84
		c	122	124	136	136	138
		d	11	11	11	11	11
		e	68	68	68	68	68
		f	5,3	5,3	5,3	5,3	5,3
		g	4	4	4	4	4
		h	144	145	158	158	160
		M	25	25	32	32	32
		M*	2x25 (blind) breekpoort		2x25 (blind) breekpoort		
	Kabel Ø tot mm		18	18	18/25	18/25	18/25
	Kabelaansluiting van/tot mm²		1,5	1,5	2,5	2,5	2,5
			-4	-4	-10	-10	-10