

## Inbouwcontactdoos TwinCONTACT

Bestelnr. 156



- schroefloos met insteekklemmen
- geschikt voor doorlussen
- 20° hoek

### Technische gegevens

Ampère	16 A
Polen	5 p
Voltage	400 V
Uurstand	6 h
Hertz	50-60 Hz
Aansluittechniek	zonder schroeven, TwinCONTACT
Contacten	standaard
Beschermingsgraad	IP44
Flens	87x71 mm
Bevestigingsgaten	70x52 mm
Hoek	20°
Gewicht	140 g
Certificeringen	VDE, EAC

### Afmetingen

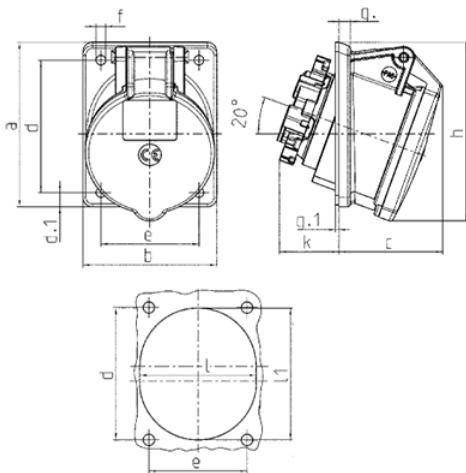

Tekening	Amp. Polen	16	
		4	5
1 MB 650			
Maten in mm	a	87	87
	b	71	71
	c	58	57
	d	70	70
	d.1	7,5	7,5
	e	52	52
	f	5,1	5,1
	g	6	6
	g.1	2	2
	h	92	95
	k	31	32
	l	61	62
	l1	-	72
Kabelaansluiting		1,5	1,5
van/tot mm <sup>2</sup>		—4	—4