

Inbouwcontactdoos met TwinCONTACT

Bestelnr. 1791



- schroefloos met insteekklemmen
- geschikt voor doorlussen
- rechte uitvoering

Technische gegevens

Ampère	32 A
Polen	4 p
Voltage	400 V
Uurstand	6 h
Hertz	50-60 Hz
Aansluittechniek	zonder schroeven, TwinCONTACT
Contacten	standaard
Beschermingsgraad	IP44
Flens	75x75 mm
Bevestigingsgaten	60x60 mm
Gewicht	180 g
Certificeringen	VDE, EAC, CQC

Afmetingen

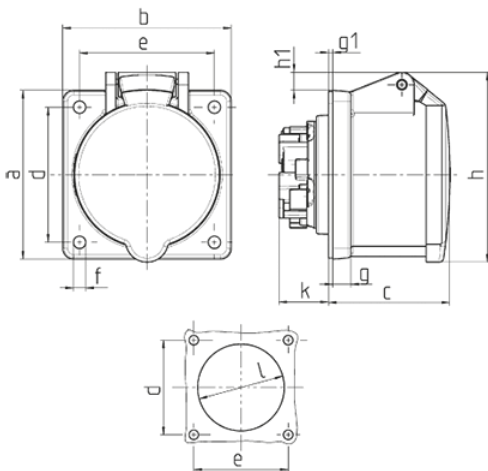

Tekening 1 MB 464	Amp. Polen	16			32		
		3	4	5	3	4	5
Maten in mm							
a		75	75	75	75	75	75
b		75	75	75	75	75	75
c		53	53	54	64	64	64
d		60	60	60	60	60	60
e		60	60	60	60	60	60
f		5,5	5,5	5,5	5,5	5,5	5,5
g.		8	8	8	8	8	8
g.1		2	2	2	2	2	2
h		75	80	85	89	89	95
h1			5	8	10	10	12
k		22	22	22	28	28	28
l		43	52	57	60	60	64
Kabelaansluiting van/tot mm ²		1,5	1,5	1,5	2,5	2,5	2,5
		-4	-4	-4	-6	-6	-6