

Cepex wandcontactdoos, lichtgrijs

Bestelnr. 4235



- schroefklemmen
- 2 contactdozen SCHUKO® 16 A, 2 p+E, 230
- andere varianten op aanvraag

Technische gegevens

Ampère	16 A
Polen	2 p+A
Voltage	230 V
Hertz	50-60 Hz
Beschermingsgraad	IP44
Aanrakingsveiligheid	false
Gewicht	422 g
Certificeringen	EAC

Afmetingen

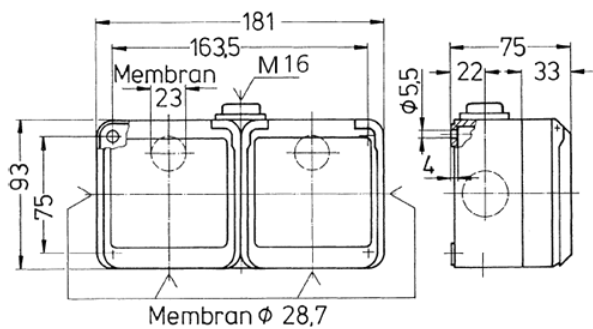

Tekening 1 MB 350	Amp. Polen	16		
		3	4	5
Maten in mm				
Kabelaansluiting van/tot mm ²		1,5 -4	1,5 -4	1,5 -4