

Wandcontactdoos

Bestelnr. 5051A



- schroefklemmen
- afschakelbaar

Technische gegevens

Ampère	16 A
Polen	5 p
Voltage	400 V
Uurstand	6 h
Hertz	50-60 Hz
Aansluittechniek	schroefklemmen
Contacten	standaard
Beschermingsgraad	IP44
Behuizing materiaal	Kunststof
Gewicht	952 g

Afmetingen

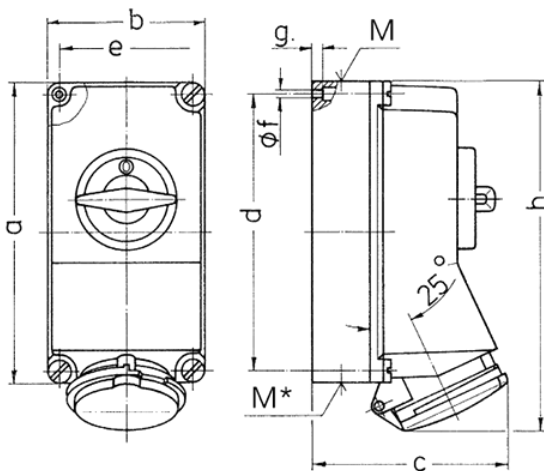

Tekening 1 MB 174	Amp. Polen	16			32			
		3	4	5	3	4	5	
Maten in mm		a	225	225	225	225	225	225
		b	118	118	118	118	118	118
		c	141	141	141	146	146	146
		d	208	208	208	208	208	208
		e	101	101	101	101	101	101
		f	6,3	6,3	6,3	6,3	6,3	6,3
		g	8	8	8	8	8	8
		h	250	252	254	264	264	264
		M	1x25 en 1x32			1x25 en 1x32		
		M*	2x25	2x25	2x25	2x25	2x25	2x25
		Kabel Ø tot mm	25	25	25	25	25	25
		Kabelaansluiting van/tot mm ²	1,5	1,5	1,5	2,5	2,5	2,5
			—4	—4	—4	—10	—10	—10